

# Logbook

The following is a rough estimation of when I did things. I tried to group my work every week.

## December 2

Today I thought about what my project would be, I came up with the following:

Fuel Cell Efficiency

-Saltwater Fuel Cell

-Microbul Fuel Cell

What is the limit of rechargeable batt.

Wed Jan 28

Today I began to investigate what I will be testing, the following is what I came up with:

- **Change being tested:** Look at the 'Independent Variables' section
- **Testing time:** 3 min
- **Checkup:** every 15 - 30sec

#### Materials

- Voltage meter
- Timer (On Phone)
- 1.0mm Magnesium Plate
- Warm Water
- Table Salt
- Old Pillow covers

#### Variables

**Independent** → Water Temp, **Amount of dissolved salt**, Type of Cathode [The amount of air flow] (Ex. Pillow covers, High-Purity Graphite Fiber Felt, Pencil lead, copper), Anode Material Change (e.g. Aluminum or Zinc Instead of Magnesium), Electrode surface area (size of magnesium plate)

**Dependent** → Amount of electricity generated (Voltage)

**Controlled** → Container, thickness of magnesium plate, Type of salt, Environment temp (overall environment), All not used independent variables

#### Chemical Reactions

Magnesium plate and Salt water:  $Mg + 2OH^- \rightarrow Mg(OH)_2 + 2e^-$

Oxygen and water:  $O_2 + 2H_2O + 4e^- \rightarrow 4OH^-$

Net Reaction:  $2Mg + O_2 + 2H_2O \rightarrow 2Mg(OH)_2$

### Container Prototype V1:

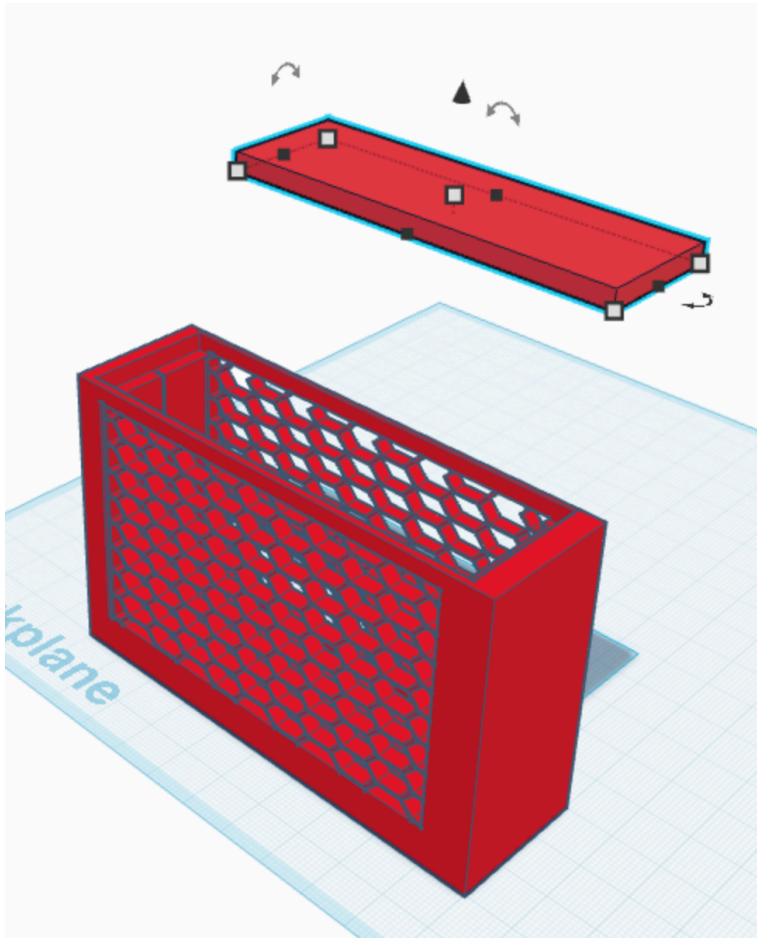

The mesh pattern provides structural support for the pillow cover and the slot is for the easy placement of the magnesium plate.

### Mon Feb 2

Over the past week I have put together version 2 of the fuel cell case and did some of the research for the trifold.

## Salt water Solutions

10ml water = 6grams salt

10ml water = 3grams salt

10ml water = 1.5grams salt

10ml water = 0grams salt (Control?)

## Definitions

- 1. Fuel Cell:** A device that converts chemical energy into electric energy through electrochemical reactions
- 2. Anode:** The positively charged electrode (AKA. Magnesium Plate)
- 3. Cathode:** The negatively charged electrode (AKA. Pillow Cover)
- 4. Electrolyte:** The conductive medium enabling ion transfer between the cathode and anode

## Variables (Updated)

**Independent** → Amount of dissolved salt

**Dependent** → Amount of electricity generated (Voltage)

**Controlled** → Container, thickness of magnesium plate, Type of salt, Environment temp (overall environment), Water Temp, Type of Cathode [The amount of air flow], Anode Material, Electrode surface area

## Hypothesis

I think an electrolyte with more sodium will generate more power because

## Project Names:

Salt-letric Solution

The Salty Spark

Salty Spark Solution

salty spark solution

Container Prototype V2:

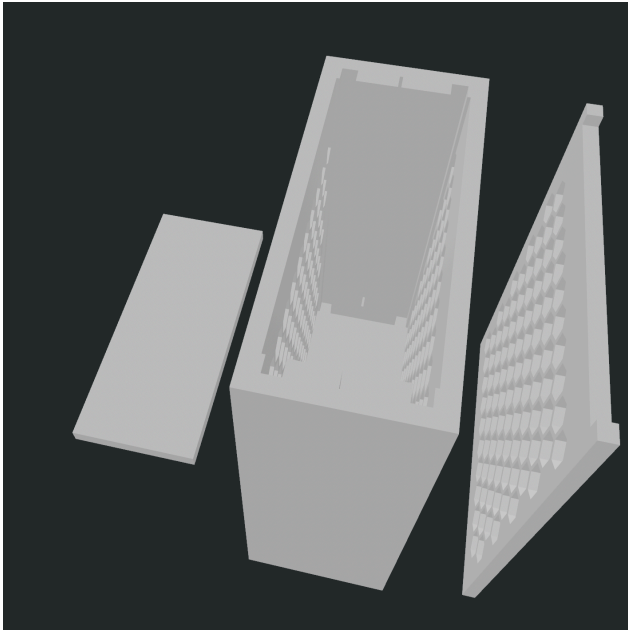
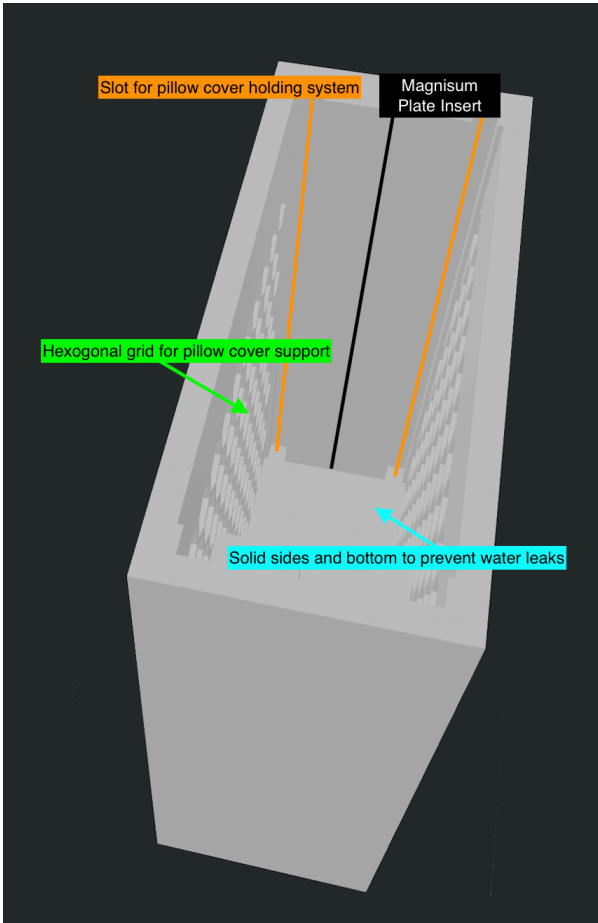

Friday Feb 6 2026

Final Setup:

I changed the

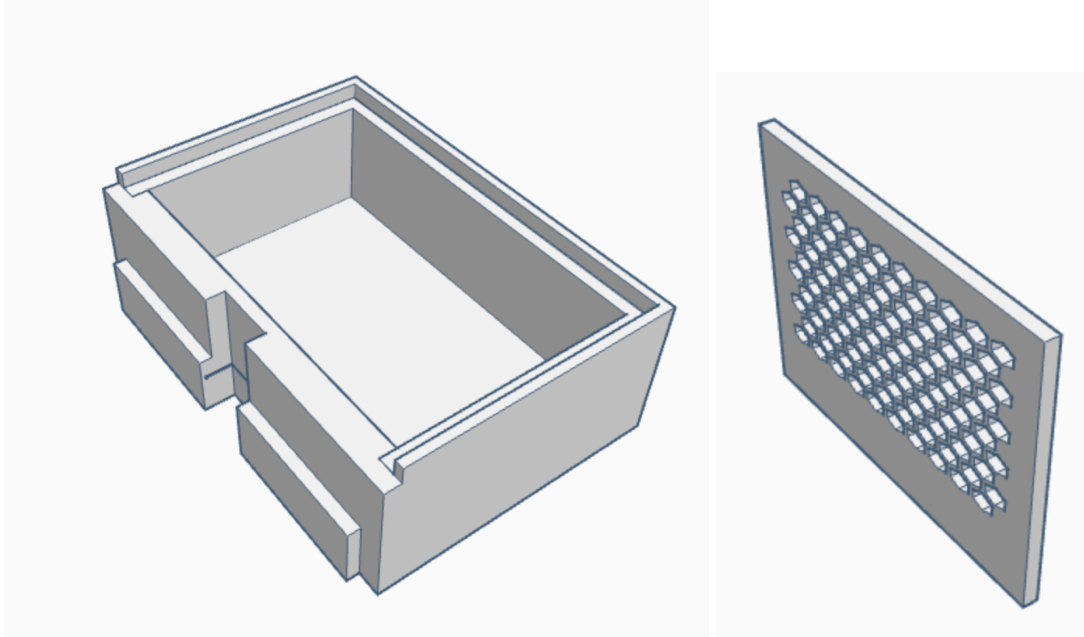

Definitions Updated:

**1. Fuel Cell:** A device that converts chemical energy into electrical energy through electrochemical reactions

**2. Anode:** The positively charged electrode (AKA. Magnesium Plate)

**3. Cathode:** The negatively charged electrode (AKA. Graphite and coffee filters)

**4. Electrolyte:** The conductive medium enabling ion transfer between the cathode and anode

What is a magnesium - air fuel cell?

- It is a fuel cell where magnesium reacts with oxygen from the air to produce electricity.

Monday Feb 17 2026

## How are Batteries and Fuel Cells different?

### **Battery**

- Is a closed system.
- All reactants are sealed/stored inside.
- Runs for a limited time.
- Non-rechargeable batteries need to be replaced
- Rechargeable batteries need to have reaction reversed for some time to store energy

### **Fuel cell**

- Is an open system.
- All reactants (fuel) can be made to continuously flow in or get replenished.
- Runs indefinitely as long as there is fuel
  - You can sustain the reaction
- Produces a constant source of power over time

## How are Batteries and Fuel Cells the same

- **Both have chemical reactions that transfer electrons from the anode to the cathode through the electrolyte**
- **And ions get**

### **Observation of the chemical reaction:**

The water got cloudy during the experiment

There were bubbles coming from the magnesium plate?

**Fact or Fiction?** Is pure water an insulator? I assumed pure water would not conduct and that I could use it as a control. I used water from my parent's reverse osmosis system.

**Research:** Reverse Osmosis is a [water purification](#) process that uses a [semi-permeable membrane](#) to separate water molecules from other substances.

- Source: [Wikipedia](#)  
[[https://en.wikipedia.org/wiki/Reverse\\_osmosis](https://en.wikipedia.org/wiki/Reverse_osmosis)]

**Research:** Water undergoes [autoionization](#) in the liquid state when two water molecules form one hydroxide anion (OH<sup>-</sup>) and one hydronium cation (H<sub>3</sub>O<sup>+</sup>). Because of autoionization, at ambient temperatures pure liquid water has a similar intrinsic charge carrier concentration to the semiconductor germanium and an intrinsic charge carrier concentration three orders

**Research:** iSpring Reverse Osmosis system home. The core model RCC7AK reduces TDS (93-98%), PFAS (96-99%), Chlorine (95-99%), Asbestos (>99.7%), Barium (>98.4%), Cadmium (>98.8%), Chromium (>99.2%), Copper (>97.8%), Fluoride (>97.4%), Lead (>98.9%), Selenium (>99.0%), and over 1,000 other contaminants.

- Source: Amazon  
[<https://www.ispringfilter.com/ac/ispring-rcc7akf3-value-pack-alkaline-6-stage-under-sink-reverse-osmosis-water-filter-system-patented-easy-mount-faucet-for-effortless-installation-additional-3-pre-filters-included>]

**Research:** When pure water is exposed to air it absorbs contaminants such as atmosphere gases. Carbon dioxide readily dissolves in water to produce carbonic acid which is slightly conductive.

- Source: [SodaSense](#)  
[<https://sodasense.ca/blogs/bubbly-blog/does-water-go-stale>]

**Research:** Water exposed to air absorbs carbon dioxide, which forms carbonic acid. Carbonic acid dissociates to form ions, which increase the conductivity of the water and thus increases its conductivity.

- Source: [UC Santa Barbar Physics](#)  
[<https://web.physics.ucsb.edu/~lecturedemonstrations/Composer/Pages/64.16.html>]

**Observation:** When the solution was pure water, the circuit conducted electricity. There was a very small amount of electricity. What does this tell me? I infer that the water must be contaminated. The water was clear but it must have still contained some ions.

**Observation:** The copper turned green in some sections, dying the coffee filter green as well. I infer that the salty water sped up the oxidation process of the copper wire. In the long run copper would affect the performance of the fuel cell but for my experiment it's not as noticeable.

**More Testing:**

- ★ Test the performance of the fuel cell using stainless steel or aluminum instead of copper.
- ★ Test the performance of the fuel cell at different temperatures
- ★ Change the Cathode to graphite felt or Biochar
- ★ Change the size of the magnesium plate
- ★ Reduce the amount of salt water (electrolyte)
- ★ Test the fuel cell with different loads (make it power a car, Automata Sculpture, ect.
- ★ Test using a different type of electrolyte (Not salt water)
- ★ Test using sea water (there will be other impurities)

**Fuel Cell Principals**

**Why does the magnesium plate dissolve?**

Salt (NaCl) separates when dissolved into (Na) sodium and (Cl) chloride.

The chloride punctures through the protective film magnesium hydroxide dissolving the magnesium plate below.

## **Procedure:**

### **A) Anode**

1. Prepare a clean fuel cell container
2. Place the magnesium plate into the holding slot so the corner protrudes for the multimeter's alligator clip
3. Seal the holding slot with hot glue
4. Pour RO water inside to ensure there are no water leaks

### **B) Cathode**

1. Prepare a clean cathode air interface
2. Take one coffee filter, fold the sides in toward the middle
3. Fill the inside with activated carbon
4. Take a copper wire and strip off the plastic protective coating
5. Bend it in a spiral and place it inside the coffee filter with the activated carbon
6. Tape the open edge with electrical tape
7. Take another coffee filter and place coffee filter one inside coffee filter two; seal open side with electrical tape.
8. Take two additional coffee filters, overlap and create overhang from the sealed coffee filters such that they dip into the electrolyte to wick electrolyte to the cathode.
9. Place the thin coffee filters on the hexagonal mesh lid
10. Place the other two coffee filters on top
11. Strap everything together using Zip Ties

### **C) Salt water electrolyte**

1. Using a measuring cup pour 250ml of (RO) water into a glass

2. Take your desired amount of salt and mix it into the water
3. Using a spoon mix the salt into the water until it dissolves

**Feb 10-20 2026**

I started to put up information on my tri-fold and organize my findings.